

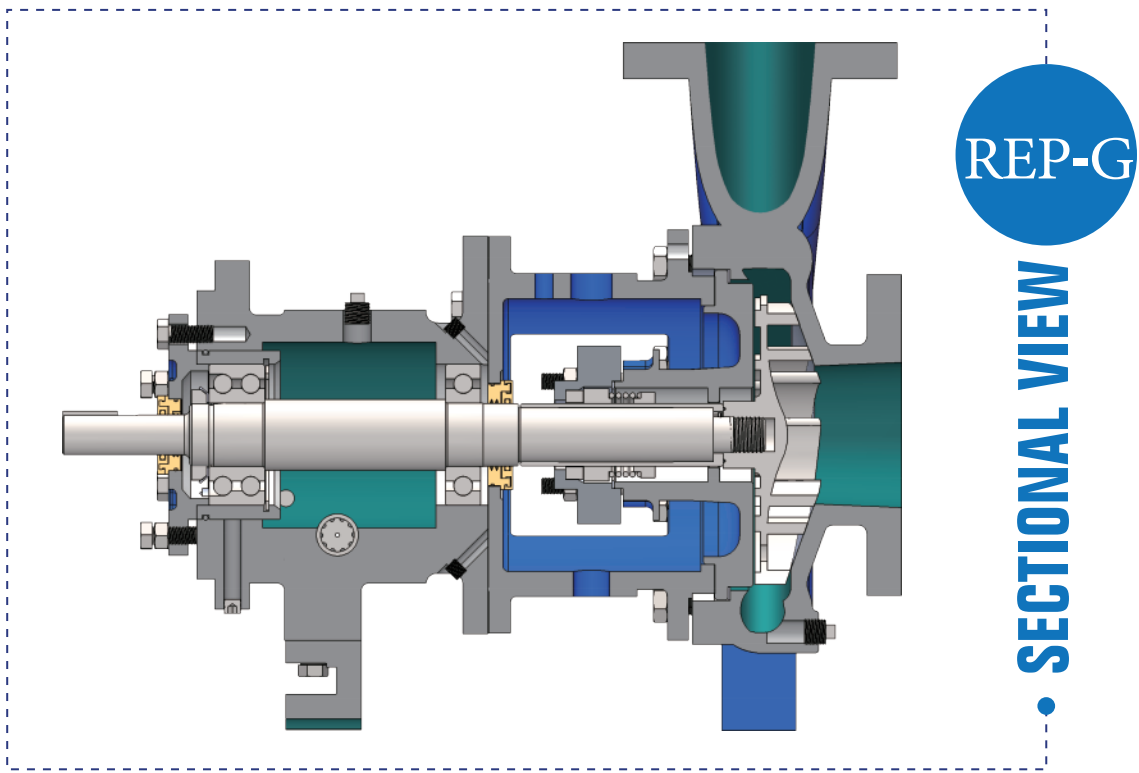

Model: 5196 REP-G Series
Chemical Process pump

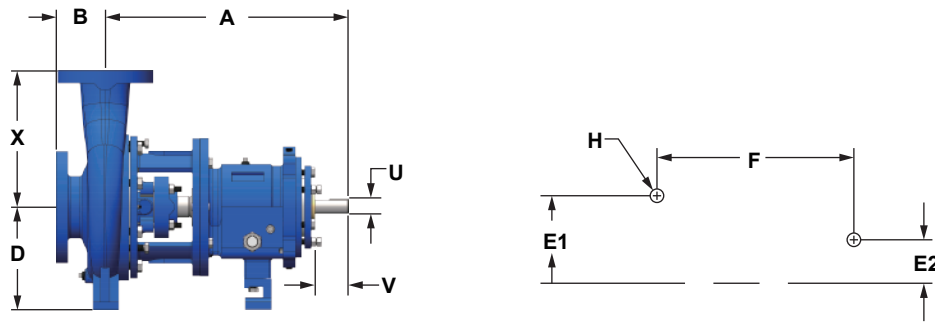

▼ **OUTLINE DIMENSIONS** [Unit: inch (mm)]



Pump Frame	Size		Pump Dimensions													
			X	D	B	A	SP	Foot Pattern				Shaft				
								DIS	SUC	IMP	E1	E2	F	H	U	KEYWAY
STN	AA	1	1.5	6	6 1/2	5 1/4	4	13 1/2	3 3/4	4	0	7 1/4	5/8	.875	3/16 x 3/32	2
	AB	1.5	3	6												
		2	3	6												
	AA	1	1.5	8												
MTN or LTN	A60	2	3	8	8 1/4	4	19 1/2	3 3/4	4 7/8	3 5/8	12 1/2	5/8	MTN 1.125	MTN 1/4 x 1/8	2 5/8	
	A70	3	4	8												11
	A70	3	4	8G												11
	A50	1	2	10												8 1/2
	A50	1.5	3	10												8 1/2
	A60	2	3	10												9 1/2
	A70	3	4	10												11
	A40	3	4	10H												12 1/2
	A80	4	6	10												13 1/2
	A80	4	6	10H												13 1/2
LTN	A20	1.5	3	13	10	6	27 7/8	5 1/4	8	4 1/2	18 3/4	7/8	LTN 1.875	LTN 1/2 x 1/4	4	
	A30	2	3	13												11 1/2
	A40	3	4	13												12 1/2
	A80	4	6	13												13 1/2
XTT-N	A90	6	8	13	14 1/2	6	27 7/8	5 1/4	8	4 1/2	18 3/4	7/8	2.375	5/8 x 5/16	4	
	A100	8	10	13												18
	A110	6	8	15												18
	A120	8	10	15												19
	A120	8	10	15G	19											

PRODUCT FEATURES

REP-G series chemical process pumps comply with ASME/ANSI B73.1M standard. With a maximum capacities of 7000GPM, maximum head of 730 feet, temperatures to 371°C and pressures to 375PSIG, this series pumps are designed for total range of industry services. Besides extended pump life, its' back pull-out design, external impeller adjustment and maximum interchangeability simplify the maintenance. Fully open impeller, full 50/60 Hz coverage and various sizes make hydraulic performance optimum. It is the best choice for chemical, petrochemical, pulp & paper, primary metals, food & beverage and general industries. Both bare shaft pump and pump package unit with base plate and motor are available. Various material constructions can be offered according to requirement.

▲ Model 5196 REP-G interchangeability & outline dimension Drawing

Model Rep-G STN

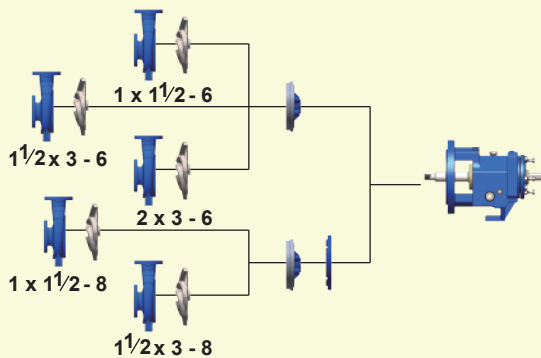

Model Rep-G MTN

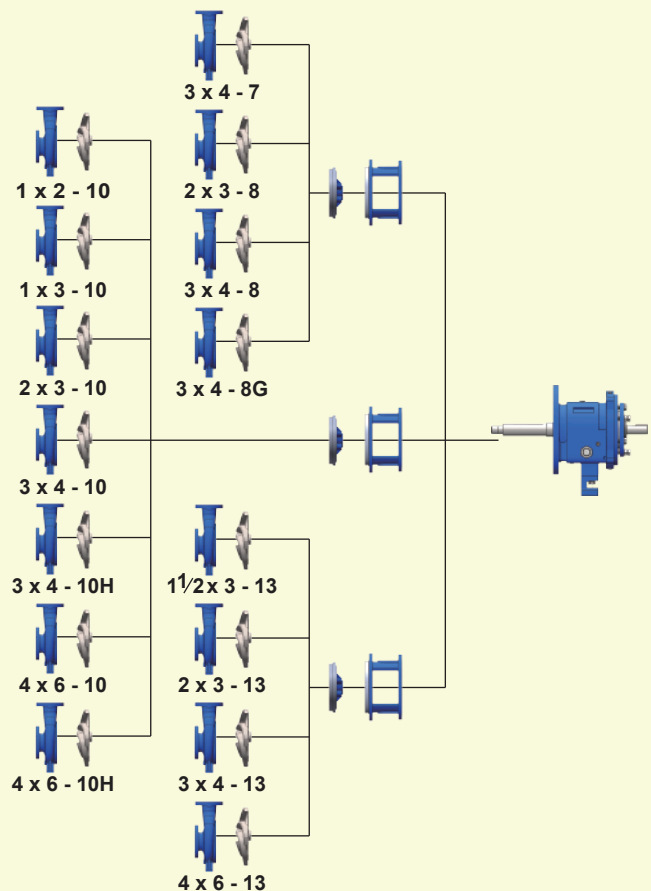

Model REP-G XLT-N

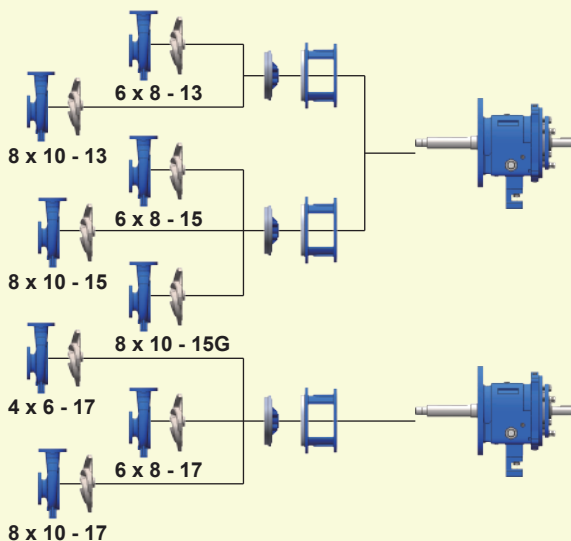

PERFORMANCE CHARTS

